

The following presentation was given May 24th, 2001 at the YCARS club house in Rock Hill, SC. The information herein was garnered from experience, historical articles in IEEE and QST publications and public domain articles. Information on transmission lines (coaxial cable and coaxial connectors) can be further researched in ARRL and IEEE publications and by looking at cable and connector manufacturers web sites.

Cable and connector manufacturer web sites typically have technical sections and FAQ sections with a plethora of useful information.

Regards,

David C. Tayloe
WB4OZU

Coaxial Connectors:

The myth
and the
mystery

History of Coaxial Transmission Development

- Fundamental groundwork laid by Hertz in 1880-90s based on “proving” Maxwell’s equation for field and waves. Experimented in 60 MHz and 400MHz range with tuned spark gap generator.
- “Stagnated” ‘til post WWII due to main development in waveguide because of narrow BW and low loss requirements primarily for radar.
- Post WWII push due to size and wide BW requirements, i.e., airborne radar and ECM equipment.

Where did 50 Ω come from?

Initially, shielded wire dimensions were all over the place, depending on who was making and using for what. (see ratio of diameter vs various characteristics)

- Attenuation is minimum at $\cong 77\Omega$
- Power capacity max at $\cong 30\Omega$
- Voltage withstanding max at $\cong 60\Omega$

IEC formed after WWII (after several false starts) to set standards.

50 Ω decided as standard compromise between the above characteristics.

However, 75 Ω was selected for systems where extremely low signals with low S/N were expected (TV antenna to receivers!)

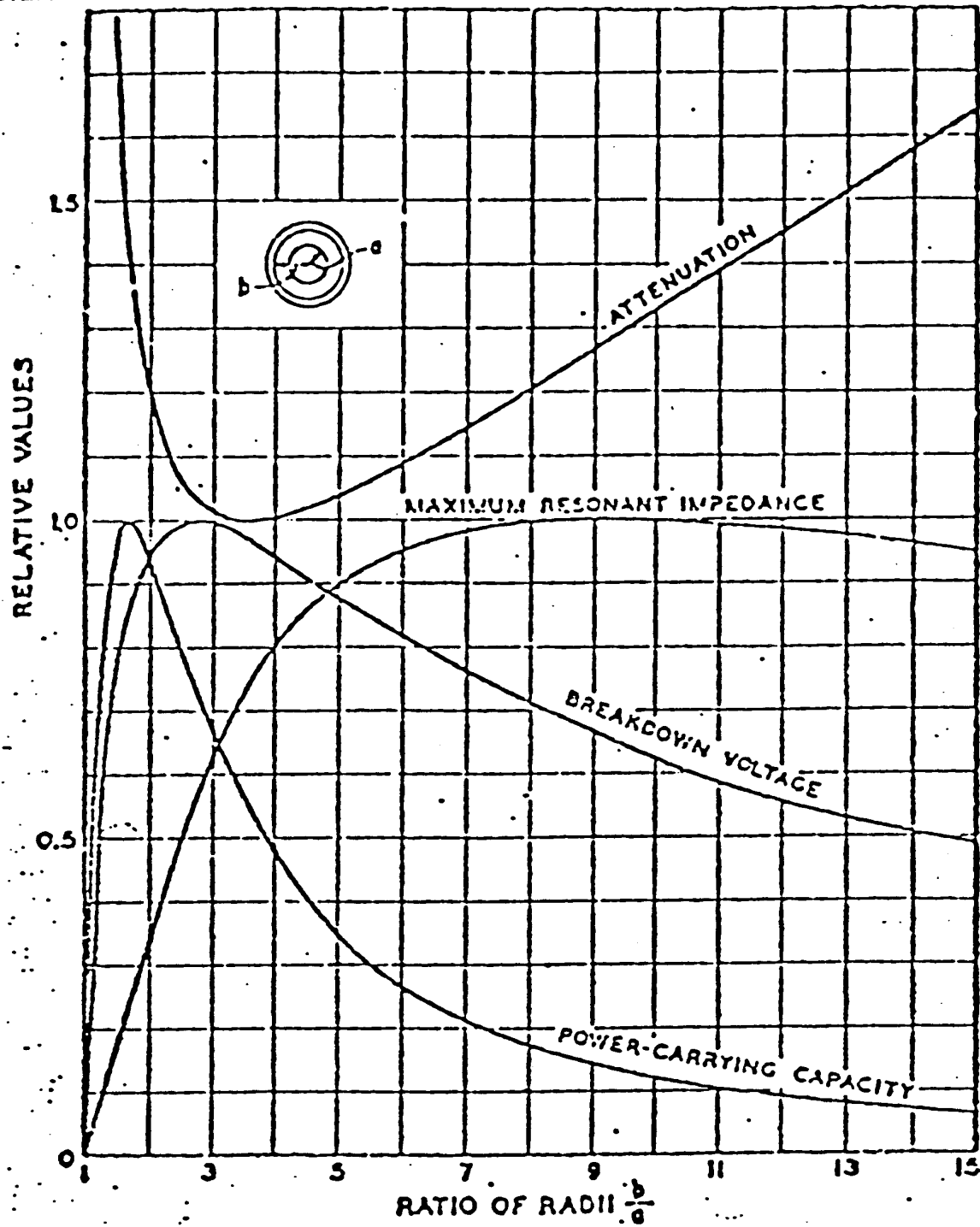

Various characteristics of a coaxial transmission line plotted as the ratio of radii of outer and inner conductors.

Ratio of Diameters vs. Impedance

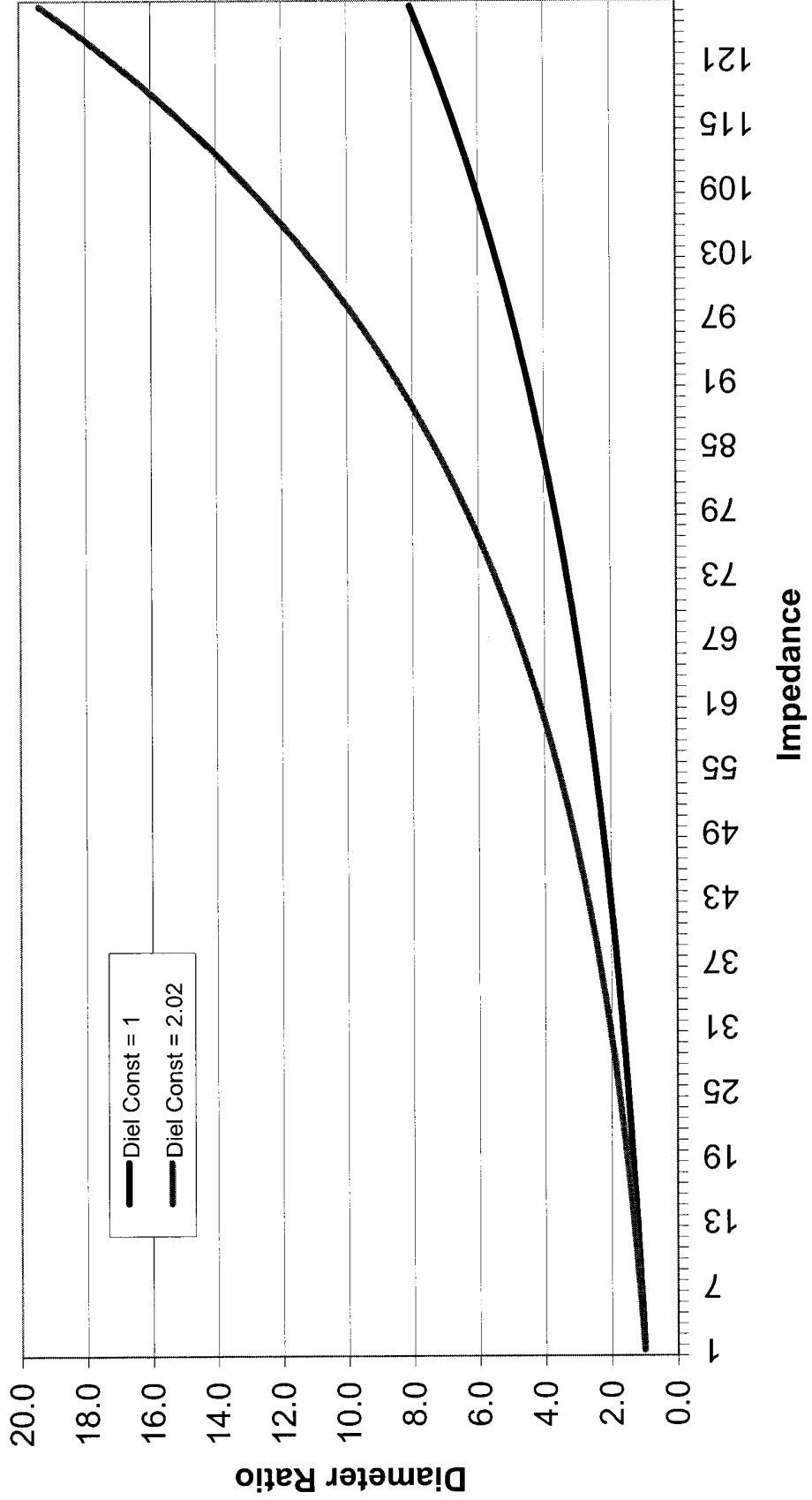

1ST Coaxial Connector?

- PL-259 UHF connector
- Misnomer in today's vernacular, but in the day, UHF was \cong 100MHz (S-36A!)
- Not usable much past 200MHz! Why? (see UHF SWR simulated plot)
- The magic formula:

$$Z_0 = 60/\sqrt{\epsilon} \ln (D/d)$$

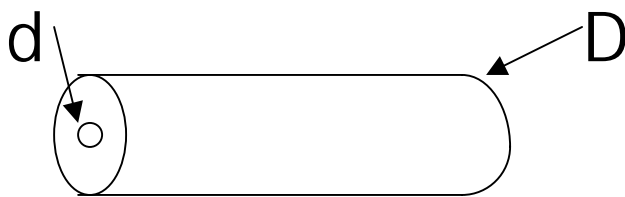

ϵ = dielectric constant of insulator

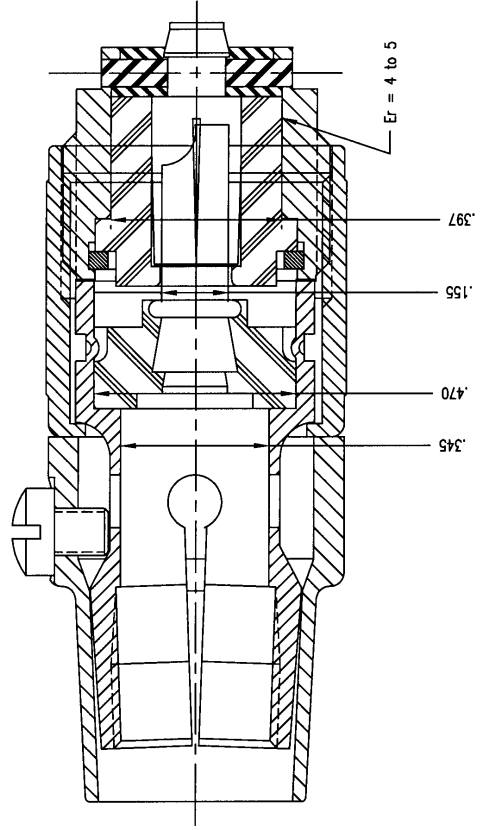
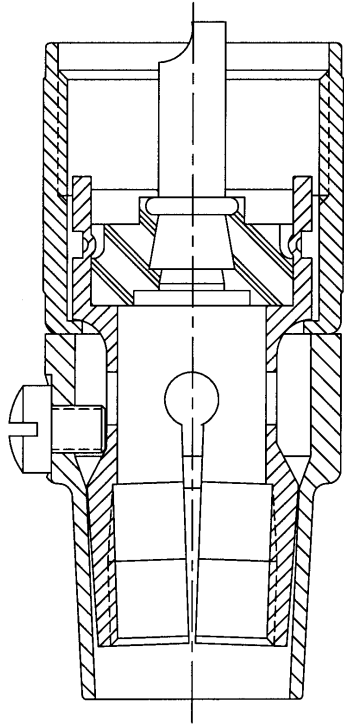

UHF connector

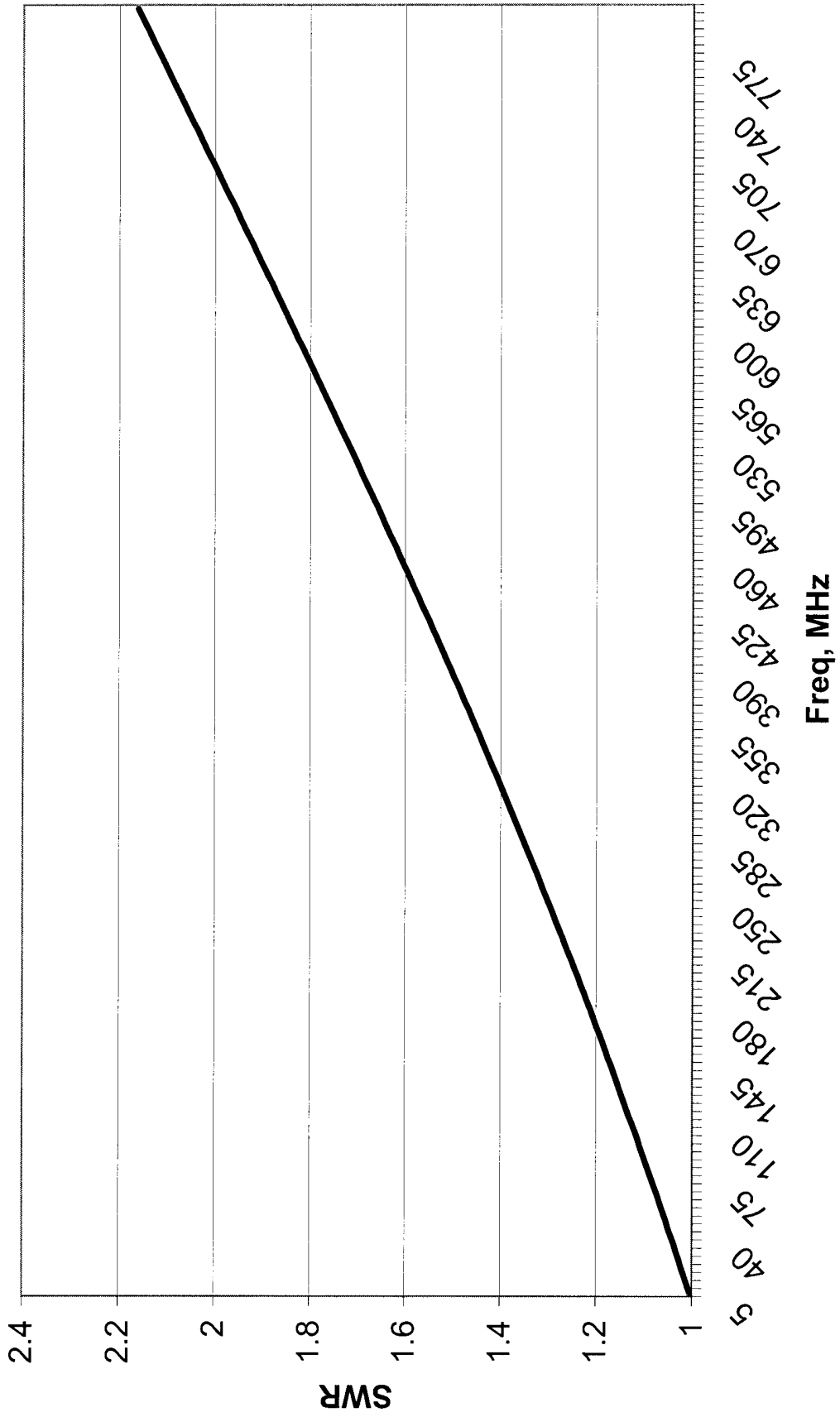

PL 259 $Z_0 \cong 20-30 \Omega$

- So what? Reflection! (Discontinuity!)

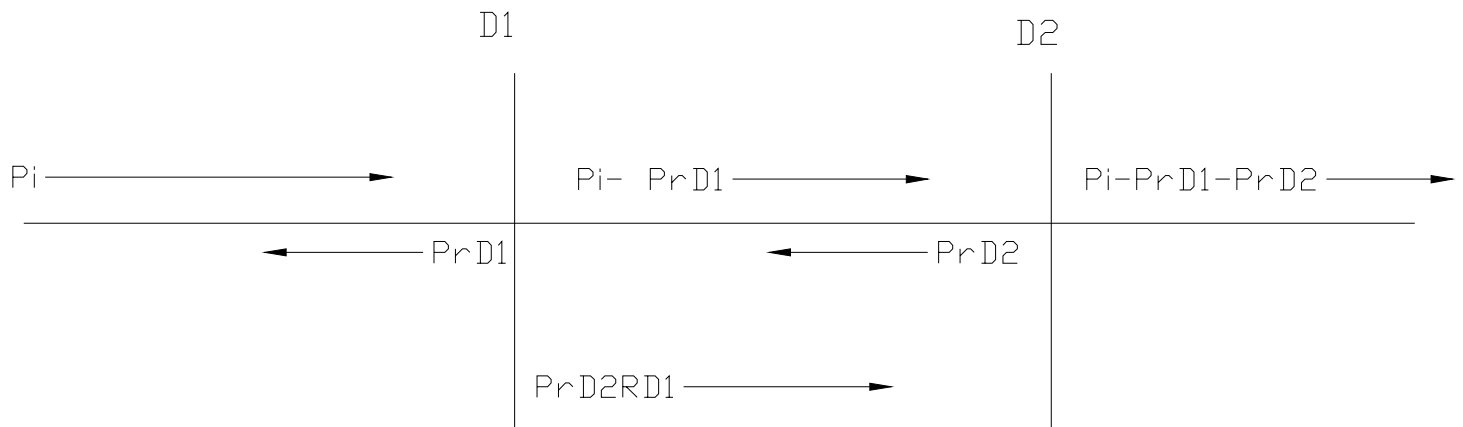

- D1, D2 some impedance change discontinuity (connector, cable, etc.)

Why 200 MHz upper use?

Rule of thumb: $\lambda > 1/10$ discontinuity wavelength, then ignore

$$\lambda = v/f$$

$$v = c/\sqrt{\epsilon}$$

- In air @ 200 MHz – $1/10 \lambda \cong 6''$
- In PTFE @ 200 MHz – $1/10 \lambda \cong 4''$

(some say 1/20 critical, so halve values)

BNC better high frequency connector because designed for constant impedance throughout connector!

(see BNC pic and simulated plots)

Discontinuities not just connector issues

- Non uniform coax cable – flattened areas
- Variations in dielectric composition (non isotropic and non homogenous)
- Etc.

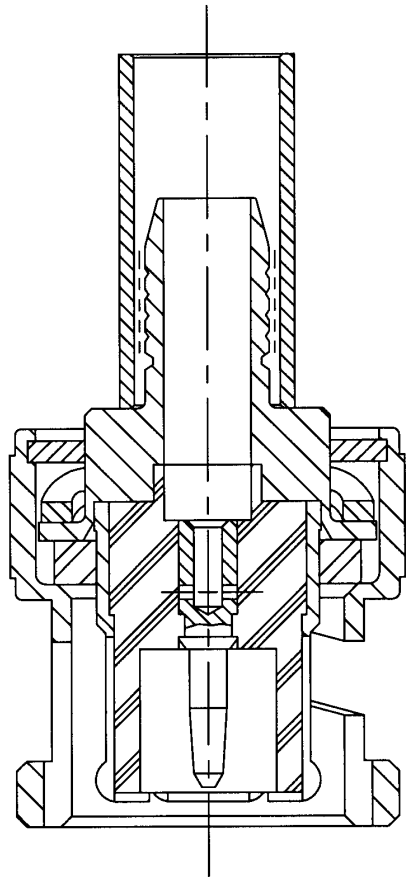
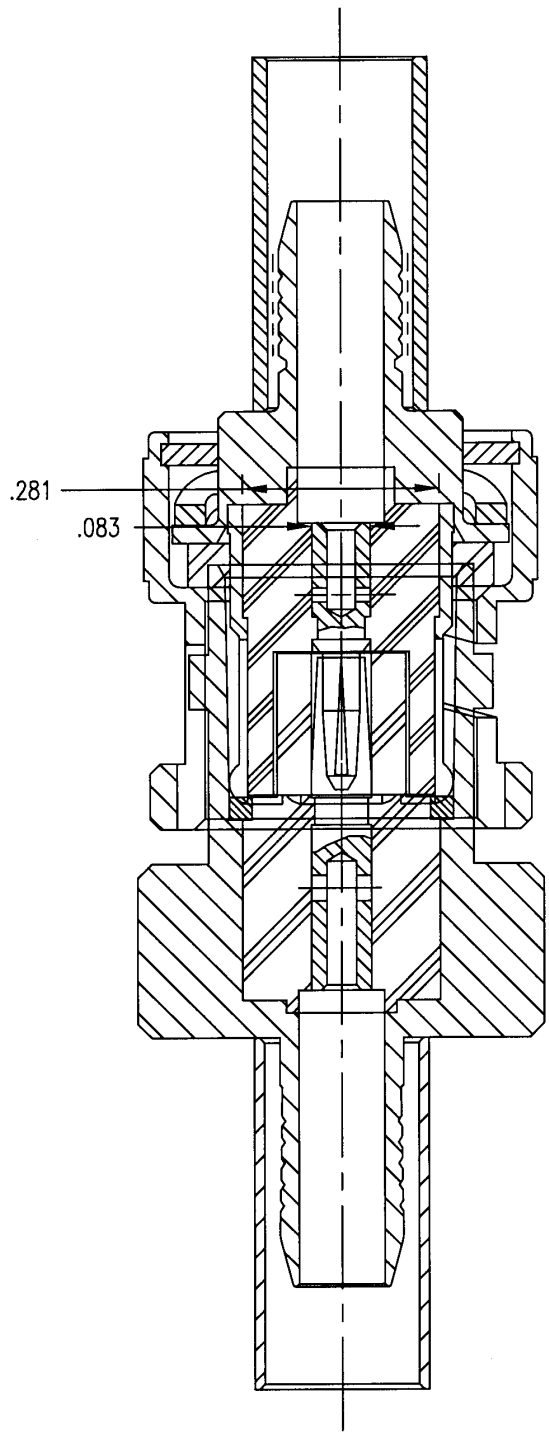

BNC connector

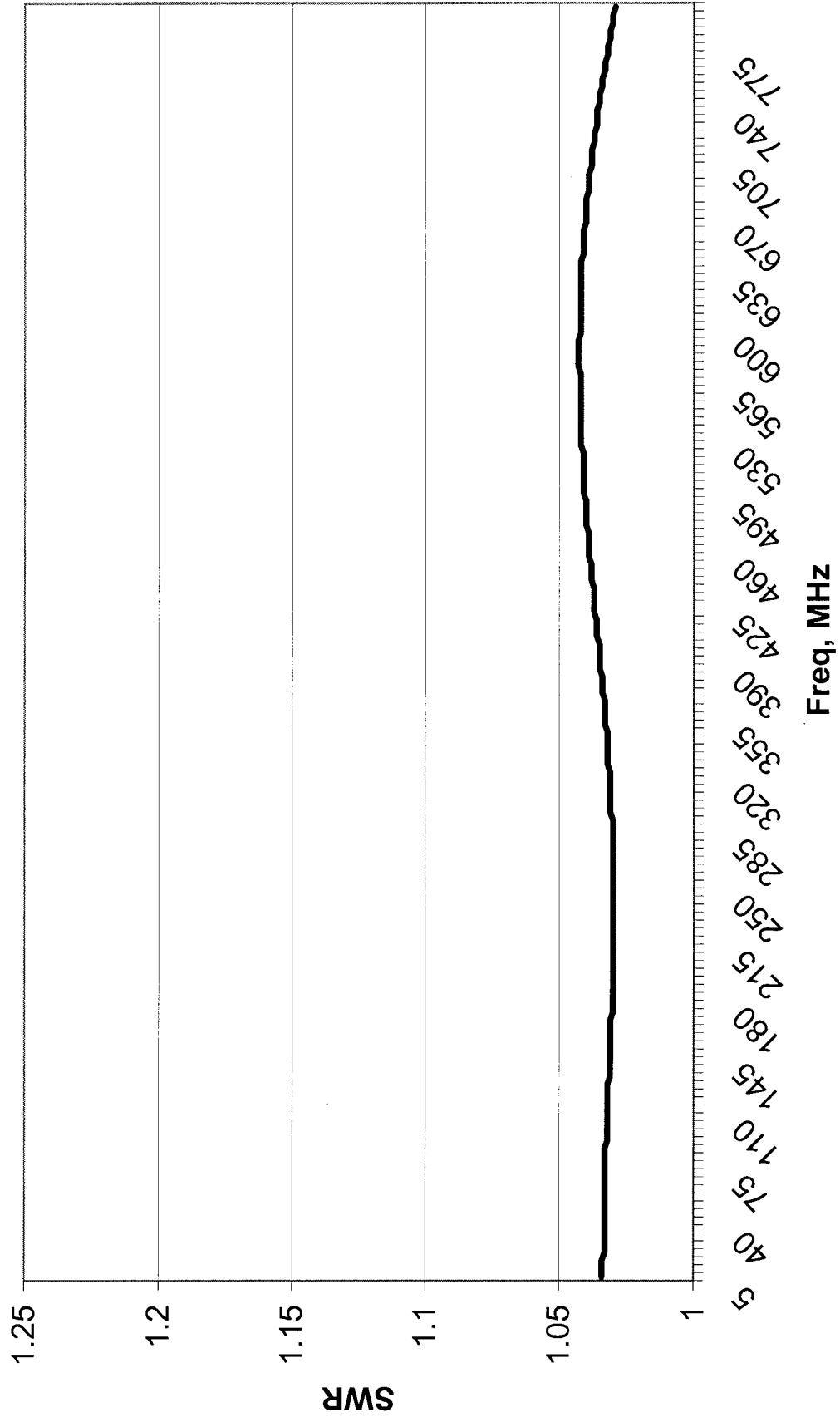

How to minimize discontinuities?

(Always back to) The Water Analogy

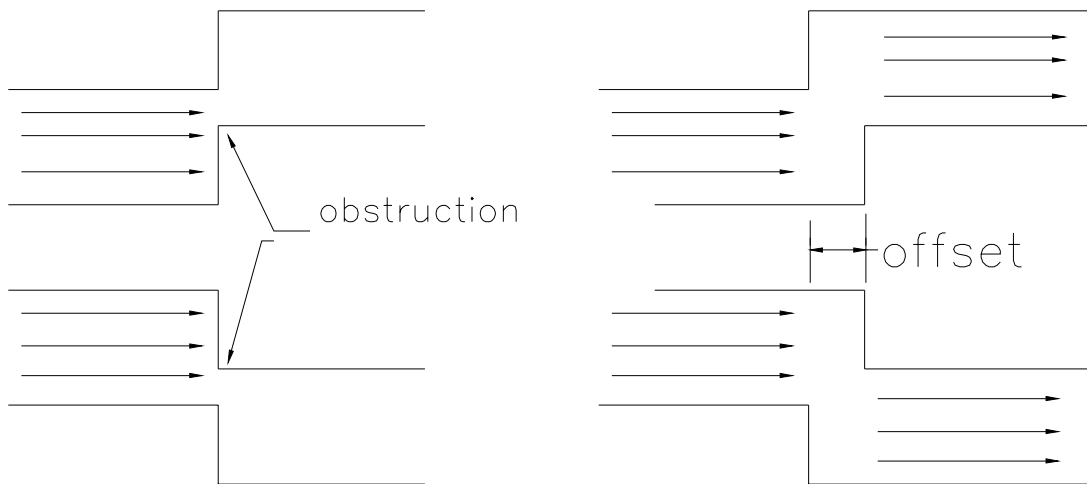

Obstruction acts like capacitor, or low impedance section, so compensate with corresponding high impedance section.

Offset derived 2 ways, theoretically and empirically.

Theoretical:
(discontinuity diagram)

DIAPHRAGM DISCONTINUITIES IN COAXIAL LINES	
<p>C_d' (α, r) given by COAXIAL DISCONTINUITY CAPACITY I. C_{d2}' (α, r) given by COAXIAL DISCONTINUITY CAPACITY II.</p>	<p> $Z_{OB} \equiv Z_{OA} \equiv Z_{OC}$ $C_d \approx 4\pi r_3 C_{d1} (\epsilon_b, r_3/r_1)$ $a = r_3 - r_2 ; b = r_3 - r_1$ </p>
<p> $Z_{OB} \equiv Z_{OA} \equiv Z_{OC}$ $C_d \approx 4\pi r_1 C_{d2} (\epsilon_b, r_3/r_1)$ $a = r_2 - r_1 ; b = r_3 - r_1$ </p>	<p> $Z_{OB} \equiv Z_{OC}$ $C_d \approx 2\pi r_1 [C_{d1} (\epsilon_b, r_{3B}/r_1) + C_{d2} (\epsilon_b, r_3/r_1)]$ $a = r_2 - r_1 ; b = r_{3B} - r_1 ; c = r_{3C} - r_1$ </p>
<p> $Z_{OB} \equiv Z_{OA} \equiv Z_{OC}$ $C_{dB} \approx 2\pi r_3 C_{d1} (\epsilon_b, r_{3B}/r_1)$ $C_{dC} \approx 2\pi r_1 C_{d2} (\epsilon_b, r_3/r_1)$ $a = r_2 - r_1 ; b = r_{3B} - r_1 ; c = r_{3C} - r_1$ </p>	<p> $Z_{OB} \equiv Z_{OA} \equiv Z_{OC}$ $C_{dB} \approx 2\pi r_1 C_{d2} (\epsilon_b, r_3/r_1)$ $C_{dC} \approx 2\pi r_3 C_{d1} (\epsilon_b, r_3/r_1)$ $a = r_2 - r_1 ; b = r_3 - r_{1B} ; c = r_3 - r_{1C}$ </p>

DIELECTRIC DISCONTINUITIES IN COAXIAL LINES	
<p>C_d' (α, r) given by COAXIAL DISCONTINUITY CAPACITY I. C_{d2}' (α, r) given by COAXIAL DISCONTINUITY CAPACITY II.</p>	<p> $Z_{OB} \equiv Z_{OA}$ $C_d \approx 2\pi r_1 \epsilon_b C_{d2} (\epsilon_b, r_3/r_1)$ $a = r_2 - r_1 ; b = r_3 - r_1$ </p>
<p> $Z_{OB} \equiv Z_{OC}$ $C_d \approx 2\pi r_3 \epsilon_b C_{d1} (\epsilon_b, r_3/r_1) + 2\pi r_2 \epsilon_c C_{d1} (\epsilon_c, r_2/r_1)$ $a = r_2 - r_1 ; b = r_3 - r_1 ; c = r_2 - r_0$ </p>	<p> $Z_{OB} \equiv Z_{OA}$ $C_d \approx 2\pi r_1 \epsilon_b C_{d2} (\epsilon_b, r_3/r_1) + \epsilon_c C_{d1} (\epsilon_c, r_3/r_1)$ $a = r_2 - r_1 ; b = r_{3B} - r_1 ; c = r_{3C} - r_1$ </p>

VALUES OF C_A, C_B, C_C APPROXIMATELY
E.A. TIMES VALUES FROM FIG. 12

Empirical:

Best guess to start and work to optimize performance (trial and error). Simulation software available, but either real expensive and difficult, or free but not real user friendly.

Transmission lines consist of distributed elements:

- C / unit length
- L / unit length

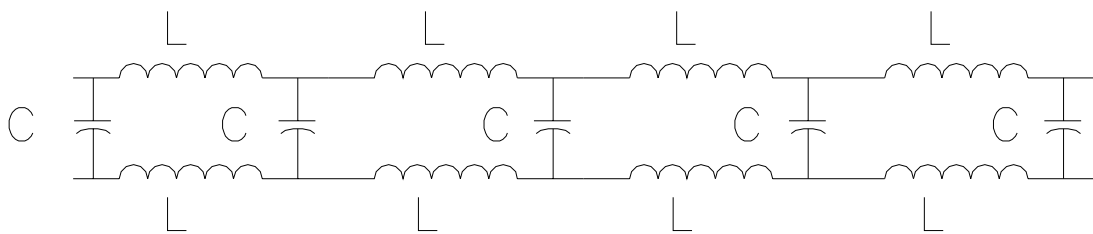

such that $Z_0 = \sqrt{L/C}$

For example, RG 213 data sez its 30.8 pF/ft. dielectric $V_p \cong 66\%$

this gives $L \cong 77\text{nH/ft.}$

Based on cable element dimensions:

Center conductor diameter - .089

Dielectric diameter (why?) - .285

$$Z_0 = 60 (.66) \ln (.285/.089) \cong 46\Omega$$

PIM

Passive InterModulation

Passive intermodulation is due to 3rd order mixing products – passive in that it is passive (non powered) devices causing the mixing products, in this case connectors.

F1 and F2 mix to give 2F1, 2 F2, 2F1-F2, 2F2-F1, etc. Frequencies of interest (or

trouble) are typically $2F_1 - F_2$ and $2F_2 - F_1$ if the carriers are close.

WHY?

Say F_1 is a repeater output, F_2 another repeater. Results = $2F_1 - F_2$ and $2F_2 - F_1$. Suppose your packet freq was at $2F_1 - F_2$? You could be interfered with every time both repeaters are transmitting.

What levels are we talking about here? Wireless levels strive for -153 dBc (153 dB below the carrier, typically 20 W or +43dBm, so absolute level is -110 dBm.)

This range is analogous to measuring the distance to the Sun to 1/10 mm (thickness of one dollar bill).

Interesting numbers, but what does it have to do with connectors?

A mixer is a nonlinear device. So is a diode. In its simplest form a rectifier junction consists of 2 dissimilar conducting materials touching. In fact early detectors on crystal sets were fashioned from blued spring steel and straight razors (dissimilar metals).

A connector consists of several dissimilar conductors touching: copper, nickel, gold, oxide combinations of each, etc.